

PRODUCT TECHNICAL DATASHEET

BE20/200/HS

Brushless 

Intensive use 

High Speed 

Digital Encoder 



CODE	DESCRIPTION	PCS/PALLET
BE20/200/HS	Electromechanical actuator HIGH SPEED BRUSHLESS, low voltage, super intensive use, with native encoder on-board, irreversible, ideal for swing gates with leaf up to 2,5 m with mechanical stopper in opening and closing. Complete with short brackets to screw on.	50

PRODUCT TECHNICAL SPECIFICATIONS	
Power line supply	230V AC - 50Hz
Motor power supply	36V
Power rating	200W
Frequency of use	Intensive use
Thrust	100 - 2200N
Operating temperature	-20 C° +55 C°
Protection level	IP44
Reductor Type	Irreversible
Manoeuvre speed	3 cm/s
Opening time	10-15 s
Stroke	400 mm
Limit switch	Mechanical stopper in opening and closing
Recommended digital controllers	230V: EDGE1/BOX - 115V: EDGE1/BOX/115
Encoder	Digital native encoder SENSORLESS 48 PPR
Operating cycles per day (opening/closing - 24 hours no stop)	800
Maximum dimension product in mm (L x W x H)	867 x 105 x 155
Product weight packed (Kg)	7,8
Number items per pallet/box	50

PRODUCT DIMENSIONS AND PREPARING FOR INSTALLATION

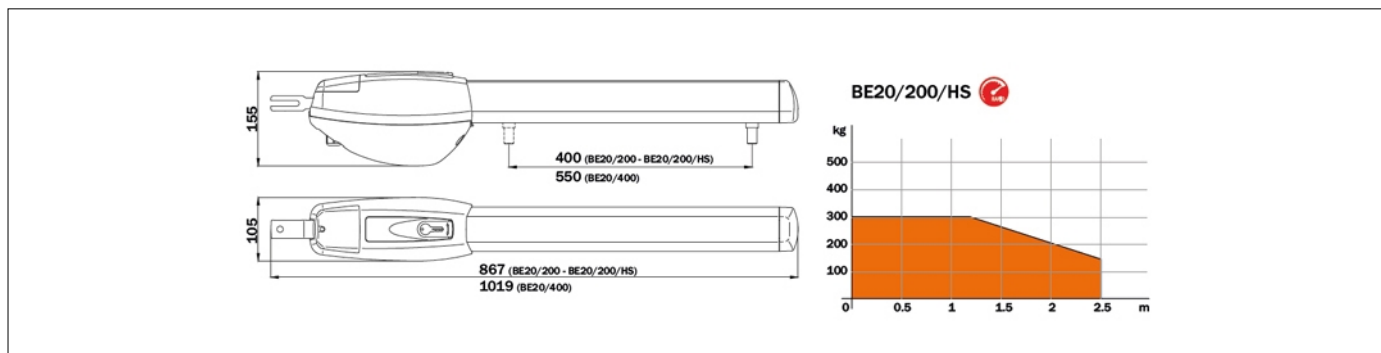

DIMENSIONS

PRODUCT PREPARING FOR INSTALLATION

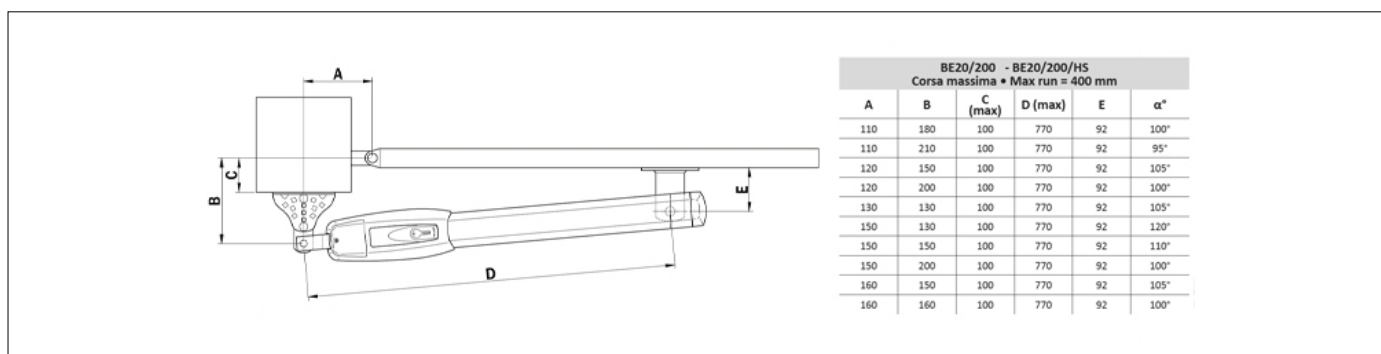

PREDISPOSITION FOR STANDARD INSTALLATION

PRODUCT ACCESSORIES



KT206

Kit three short series brackets to weld on.