

# PRODUCT TECHNICAL DATASHEET

# MONOS4

Brushless 

Intensive use 

Digital Encoder 



CODE	DESCRIPTION	PCS/PALLET
<b>MONOS4</b>	Electromechanical actuator with telescopic arm, BRUSHLESS low voltage, super intensive use, with native encoder on-board, irreversible, ideal for swing gates with leaf up to 4 m. Complete with short brackets to screw on.	50

PRODUCT TECHNICAL SPECIFICATIONS	
Power line supply	230V AC - 50Hz
Motor power supply	24V
Power rating	200W
Frequency of use	Intensive use
Thrust	2200N
Operating temperature	-20 C° +55 C°
Protection level	IP44
Reductor Type	Irreversible
Manoeuvre speed	2,10 cm/s
Opening time	19-35 s
Stroke	400 mm
Limit switch	-
Recommended digital controllers	230V: B70/2ML/BOX - 115V: B70/2ML/BOX/115
Encoder	Digital native encoder SENSORLESS 48 PPR
Operating cycles per day (opening/closing - 24 hours no stop)	700
Maximum dimension product in mm (L x W x H)	1223 x 178 x 111
Product weight packed (Kg)	7
Number items per pallet/box	50

# PRODUCT DIMENSIONS AND PREPARING FOR INSTALLATION

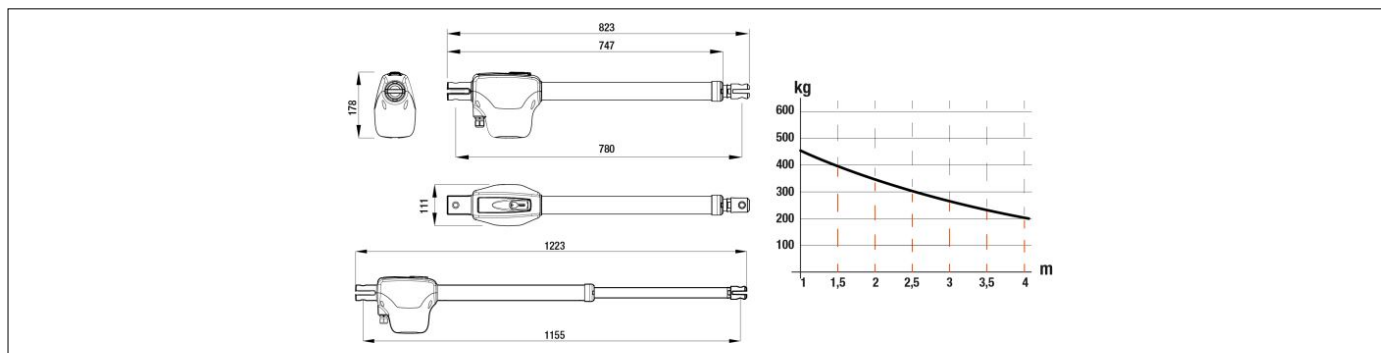

DIMENSIONS

# PRODUCT PREPARING FOR INSTALLATION

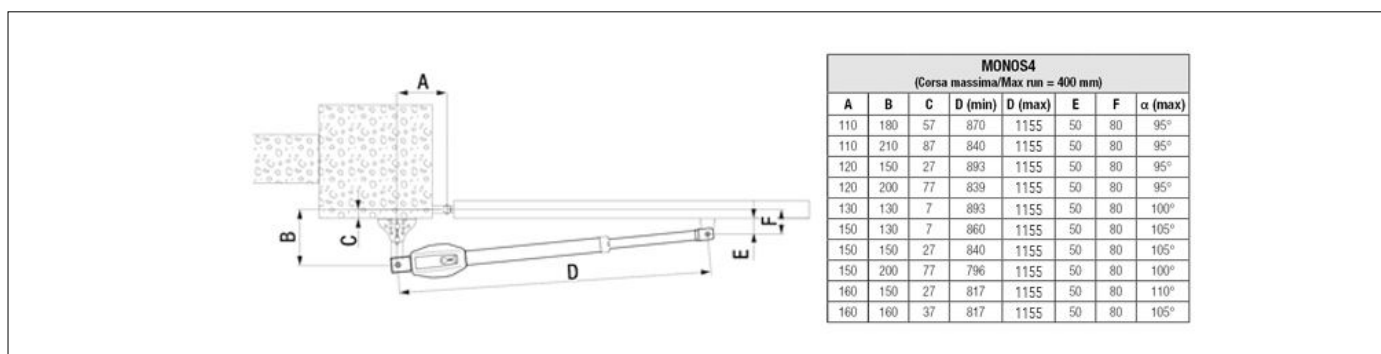

PREDISPOSITION FOR STANDARD INSTALLATION

# PRODUCT ACCESSORIES



**HT420**  
Stem cover for MONOS4 series.



**KT248**  
Front bracket support with M8 pins for MONOS4.