

PRODUCT TECHNICAL DATASHEET

R20/300



| CODE | DESCRIPTION | PCS/PALLET |
|---------|--|------------|
| R20/300 | Electromechanical actuator 230V AC irreversible for swing gate with leaf up to 2,5 m, with 1 microswitch, complete with fixing plates. | 50 |

PRODUCT TECHNICAL SPECIFICATIONS

| | |
|---|--|
| Power line supply | 230V AC - 50Hz |
| Motor power supply | 230V AC |
| Power rating | 200W |
| Frequency of use | 40% |
| Thrust | 2500N |
| Operating temperature | -20+55 C° |
| Protection level | IP44 |
| Reductor Type | Irreversible |
| Manoeuvre speed | 1,66 cm/s |
| Opening time | 19 s |
| Stroke | 320 mm |
| Motor thermal protection | 150 C° |
| Incorporated condenser | 15 µF |
| Limit switch | Microswitch in opening (optional in closing) |
| Encoder | - |
| Maximum dimension product in mm (L x W x H) | 858,5 x 120 x 165 |
| Product weight packed (Kg) | 9,2 |
| Number items per pallet/box | 50 |

PRODUCT DIMENSIONS AND PREPARING FOR INSTALLATION

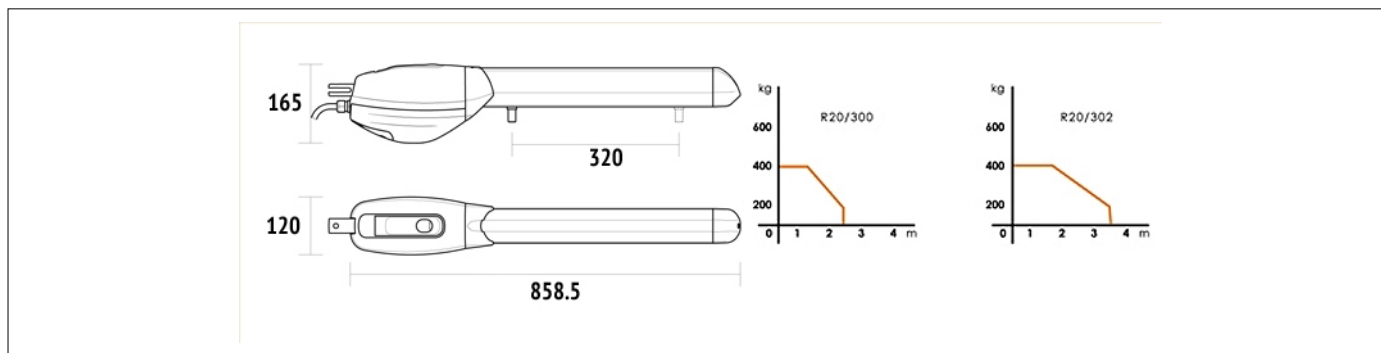

DIMENSIONS

PRODUCT PREPARING FOR INSTALLATION

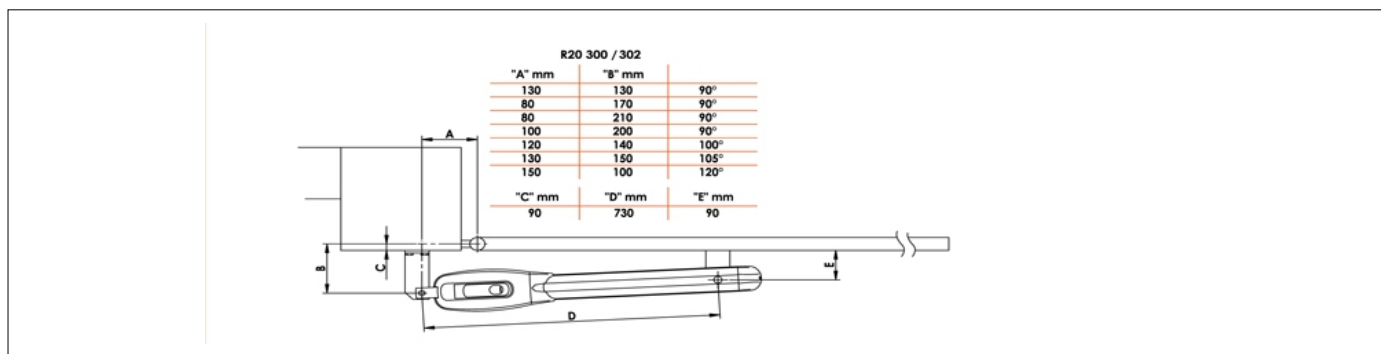

PREDISPOSITION FOR STANDARD INSTALLATION

PRODUCT ACCESSORIES

| | | | | | |
|--|--|---|--|---|--|
| | | | | | |
| MC770 Kit optional microswitch in closing with cable series R20. | MC780 Kit 2 mechanical stop R20 series. | KT202/R Screw-welded short front bracket. | KT204/R Screw-adjustable short rear bracket. | KT206 Kit three hinge plates short to weld. | KT206/R Kit of screw-adjustable short rear bracket and screw-welded short front bracket. |
| | | | | | |
| R99/C/001AL Signboard "Automatic Opening" Aluminium version. | R99/C/001 Signboard "Automatic Opening". | | | | |