

Siren Neptune

Power Siren with Flashlight

INSTALLATION INSTRUCTION & USER MANUAL

Siren Features

The Neptune siren is a new generation professional high powered acoustic siren with flashlight, which includes all performance & reliability of a state-of-the-art security alarm system.

Features:

- Outdoor siren with flashing light.
- Housing: External 3mm plastic PC UV protected
- Continuous frequency modulated sound.
- Tamper protection in 3 ways: screw removal, Cover opening or removing housing from the wall.
- Positive and negative Alarm trigger.
- Trigger input to activate only Flashlight.
- Support battery charge 12V/1.3Ah
- Siren period can set to follow trigger, 3min cutoff 15min.
- 2 LED's for ARM indication.
- Easy Installation.
- Environmental immunity.

Functional Description Alarm Trigger:

The alarm can be triggered by applying high "LOW" to "+GO" or "-GO" inputs terminals respectively.

Alarm siren duration is depending on the trigger selector state:

- F.T- Follow Trigger.
- 3min- Siren cutoff after 3 minutes, this state is recommended in order to avoid violation of local regulations.
- No JMPR- 15 min cut off (UK regulation)

Arm Indication LED's

Connect ARM input to pre-programmed output at CP, in order to have an ARM indication – LED flashing during system ARM.

triggering the input to "LOW" LEDs will blink.

ARM Indication

While the ARM Indication Jumper will be set to "Y", the Siren will beep and blink 1 time to indicate ARM.

Terminal Connections:

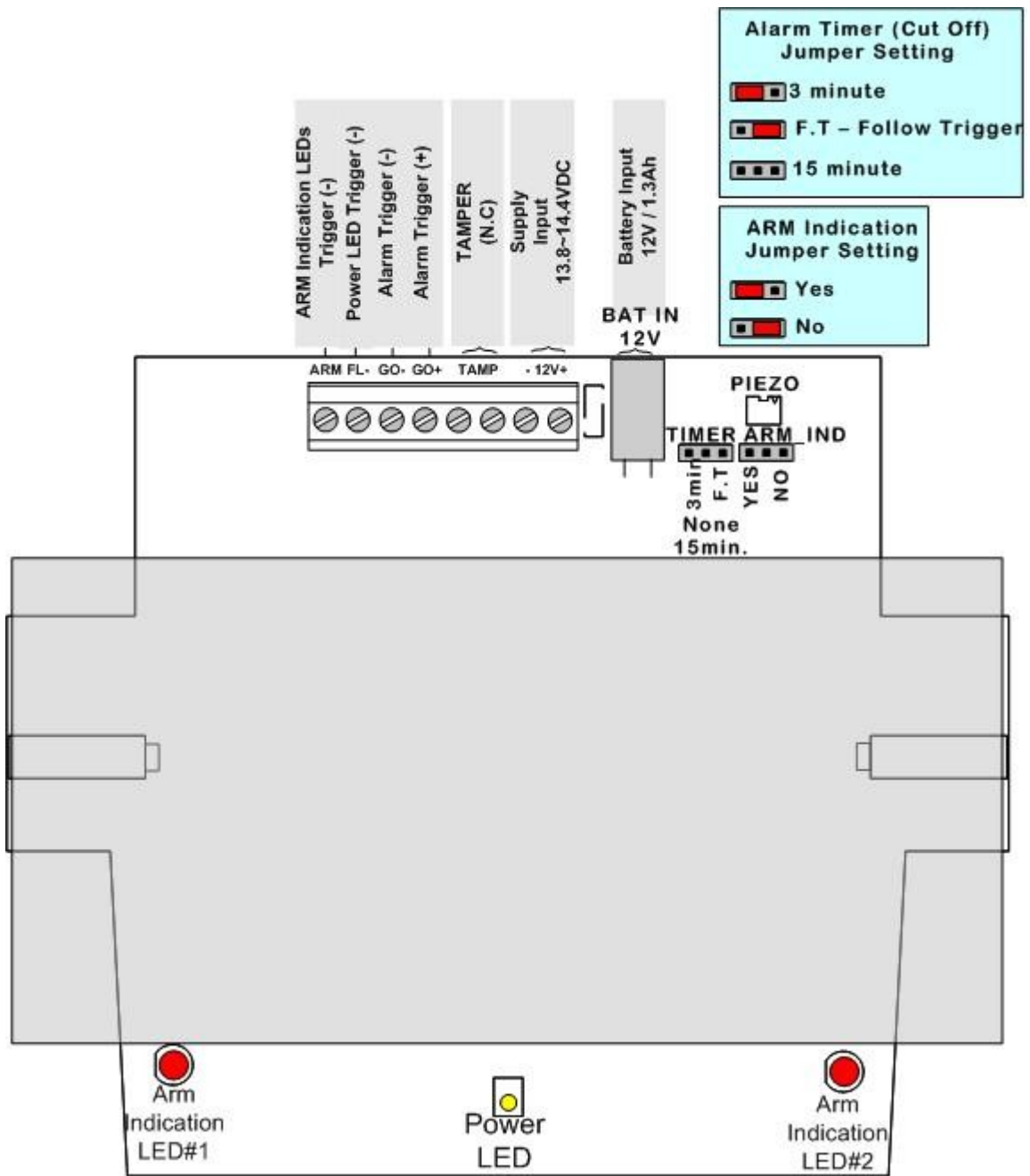

Fig. 1 – Terminal Block Connection

Note: Please refer to Control Panel's programming manual for details regarding the programming of outputs.

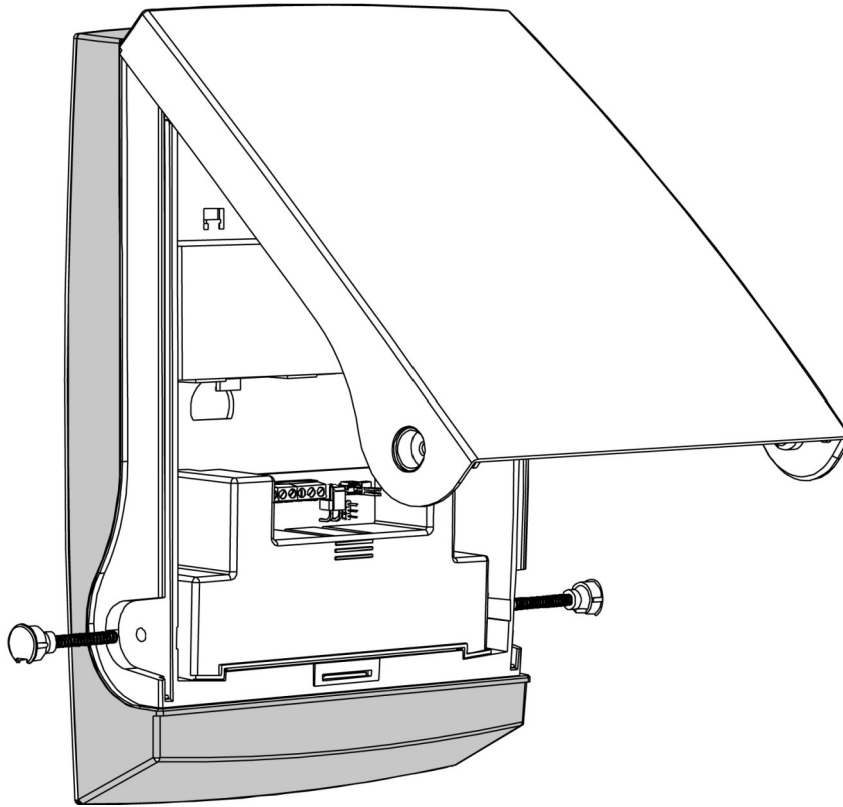

Fig. 2

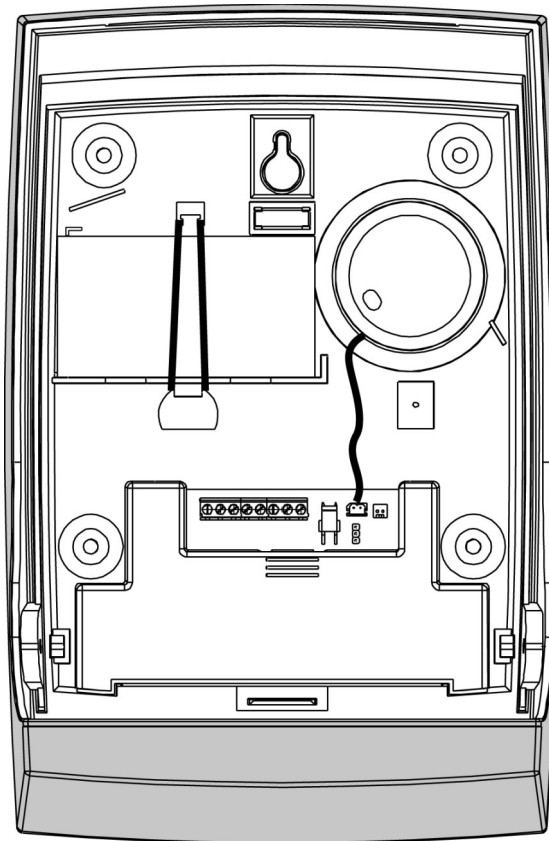

Fig. 3

Technical Specifications:	
Sound Pressure Level	More then 102dB
Fundamental Frequency	2700 Hz
Siren Tone	Yelp
Frequency Range	2700 ±300 Hz

Flash Light	Power LED
ARM Indication	2 Power LED's 1 beep and Power LED Blink –ARM 3 beeps and Power LED blink-DISARM
Power Supply Voltage	9.5 - 13.8VDC (13.8V DC for battery charging)
Battery	12VDC 1.3Ah (Sealed Lead Acid)
Current consumption (Speaker and Strobe).	Standby: 7mA Alarm: 400mA
Maximum Power	7W
Siren Alarm Period	Follow Trigger , 3 min Cutoff , 15min Cutoff
Low Battery CUT-OFF Level	8 VDC +/- 0.5VDC
Input Impedance (Alarm / Flash / Trigger)	All Inputs = 2.2K Ohm
Power Fail detection Level	6 VDC
Tamper Protection	3 switches (Normally Closed)
Dimensions of unit	L=310mm x W= 205mm x H= 75mm
Weight (Wit Battery)	1.2 Kg
Operating temperature range	-30°C to +70°C
Case Material / Protection Level	IP 43 Plastic PC with UV protection Conformal coated circuit board

CROW ELECTRONIC ENGINEERING LTD. (Crow) WARRANTY POLICY CERTIFICATE

This Warranty Certificate is given in favor of the purchaser (hereunder the "Purchaser") purchasing the products directly from Crow or from its authorized distributor.

Crow warrants these products to be free from defects in materials and workmanship under normal use and service for a period of 12 months from the last day of the week and year whose numbers are printed on the printed circuit board inside these products (hereunder the "Warranty Period").

Subject to the provisions of this Warranty Certificate, during the Warranty Period, Crow undertakes, at its sole discretion and subject to Crow's procedures, as such procedures are from time to time, to repair or replace, free of charge for materials and/or labor, products proved to be defective in materials or workmanship under normal use and service. Repaired products shall be warranted for the remainder of the original Warranty Period.

All transportation costs and in-transit risk of loss or damage related, directly or indirectly, to products returned to Crow for repair or replacement shall be borne solely by the Purchaser.

Crow's warranty under this Warranty Certificate does not cover products that is defective (or shall become defective) due to: (a) alteration of the products (or any part thereof) by anyone other than Crow; (b) accident, abuse, negligence, or improper maintenance; (c) failure caused by a product which Crow did not provide; (d) failure caused by software or hardware which Crow did not provide; (e) use or storage other than in accordance with Crow's specified operating and storage instructions.

There are no warranties, expressed or implied, of merchantability or fitness of the products for a particular purpose or otherwise, which extend beyond the description on the face hereof.

This limited Warranty Certificate is the Purchaser's sole and exclusive remedy against Crow and Crow's sole and exclusive liability toward the Purchaser in connection with the products, including without limitation - for defects or malfunctions of the products. This Warranty Certificate replaces all other warranties and liabilities, whether oral, written, (non-mandatory) statutory, contractual, in tort or otherwise.

In no case shall Crow be liable to anyone for any consequential or incidental damages (inclusive of loss of profit, and whether occasioned by negligence of the Crow or any third party on its behalf) for breach of this or any other warranty, expressed or implied, or upon any other basis of liability whatsoever. Crow does not represent that these products can not be compromised or circumvented; that these products will prevent any person injury or property loss or damage by burglary, robbery, fire or otherwise; or that these products will in all cases provide adequate warning or protection.

Purchaser understands that a properly installed and maintained product may in some cases reduce the risk of burglary, fire, robbery or other events occurring without providing an alarm, but it is not insurance or a guarantee that such will not occur or that there will be no personal injury or property loss or damage as a result.

Consequently, Crow shall have no liability for any personal injury; property damage or any other loss based on claim that these products failed to give any warning.

If Crow is held liable, whether directly or indirectly, for any loss or damage with regards to these products, regardless of cause or origin, Crow's maximum liability shall not in any case exceed the purchase price of these products, which shall be the complete and exclusive remedy against Crow.

ISRAEL:

12 Kineret St., P.O.B 293,
Airport-City, 70100.
Tel: 972-3-9726000
Fax: 972-3-9726001

E-mail:

support@crow.co.il